



FR™ Series: FR 25-35 76" Wheelbase LP-powered liftruck Capacity: up to 35,000 lbs. @ 24"

FR™ Series liftrucks®

The FR™ Series liftruck® is designed for mobility, strength and effortless handling with an extendable frame to increase loading capacity. Paired with a removable boom, the FR™ Series liftruck® is the ultimate tool for moving heavy machinery safely and effortlessly.

Chassis

- Extending counterweight chassis
- Removable/Stackable counterweights for greater flexibility and ease of transport
- Chassis tie-down points for transporting

Operator environment

HOIST® engineers designed the FR 25-35™ Series for maximum productivity, with a cab environment configured around the fatigue-reducing needs of operators.

- Rubber-mounted cab, isolated from the frame to reduce vibration and noise with levels as low as 77 db
- Fully adjustable semi-suspension seat equipped with retractable seat belt.
- Optional "Air-Ride" seat with pneumatic lumbar support and fully adjustable backrest height for added comfort
- Left hand operator position
- Non-skid steps for easy entry/exit design from left side of the truck
- Padded floor mat
- Tilt-steering column
- Illuminated digital instrument display
- "Soft-touch" hydraulic levers
- On-board capacity calculator
- Horn button and steering knob mounted on steering wheel

Engine

- Standard GM 3.0L L4 Engine
- LP gas standard (tank not included)
 - EZ-mount, LP tank bracket
- Dual fuel standard

Transmission and drive axle

- 2-speed hydrostatic drive with variable RPM control
- Externally mounted charge pump and integral filter allow for easy maintenance

- Drive: heavy-duty, planetary wheel ends designed for high load capacities, extended service life and reduced maintenance. All gears are heat-treated, precision-ground

Hydraulic system

Soft-touch control levers allow smooth, comfortable, controlled operation.

- Load-sensing, on-demand system provides smooth and reliable control while limiting demand on the powerplant
- Piston pump provides superior control and quiet operation
- Fuse in lift cylinder protects against sudden loss of pressure. If lift hose breaks, lift cylinder locks safely in position

Steering system

Heavy-duty steer axle features heavy alloy steel plate sections around single, double-acting cylinder.

- Maximized steering angles provide maximum maneuverability in tight areas while maintaining directional tracking of tire, with no scrubbing or premature tire wear

Brakes

- Hydrostatic dynamic braking

Mast design

Heavy-duty nested rail mast provides superior visibility and full capacity at maximum lift heights.

- Contact the factory for special mast requirements

Carriages

Pin-style carriage allows superior visibility for the operator and maximizes productivity.

- Integral side-thrust rollers provide uncompromised strength and reduce mast wear
- Available carriage configurations include:
 - Fork positioning carriage
 - Side-shifting carriage (under load)
 - SS/FP carriage

Boom

- Boom stand for facilitating quick change operation. Collapsible for transport.

- Hydraulically powered multi-stage telescopic boom
- High-strength adjustable composite wear pads
- Quick change system requires no tools to switch between boom and forks
- 'Under Pressure' hydraulic quick disconnects

Forks

Pallet style forks are standard on all trucks. Custom sizes available upon request.

Options

- Remote control for all vehicle functions
- Air ride seat
- Back-up camera/monitor
- Customer specified chassis color

Consult your authorized Hoist representative for additional options

Serviceability

The HOIST® FR 25-35™ Series liftruck® is engineered with your mechanic in mind: all components are well-placed for easy access and quick maintenance:

- Hydraulic Diagnostic Multi-Gauge standard on all trucks
- Hinged engine cover and removable floor panel provide excellent access to powertrain
- Hydraulic pumps, hoses and tubes and wiring harness are accessible and easy to inspect

Safety

The FR 25-35™ Series chassis is painted high-visibility "HOIST® yellow". The mast and over-head guard are painted anti-glare black. The truck complies with all currently valid ANSI, OSHA, CE, and EU directives for industrial trucks, and arrives standard with the following:

- Audible backup alarm
- Two adjustable headlights
- Amber strobe warning light

MADE WITH PRIDE IN THE USA



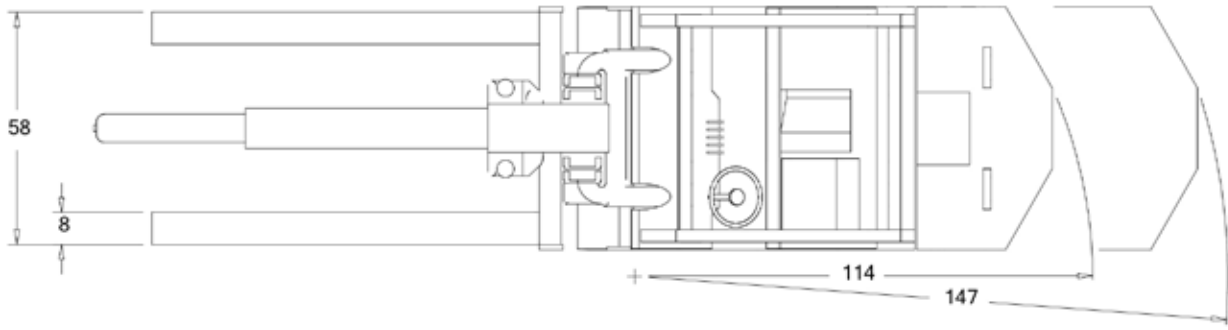

FR™ Series: FR 25-35 76" Wheelbase



FORKS ONLY

Counterweight Extension (in)	Load Center (in)	# of Slabs	Lift Capacity (lbs)
0.0 (76" WB)	24.0	0	16,300
0.0 (76" WB)	24.0	6	24,300
36.0 (112" WB)	24.0	0	24,000
36.0 (112" WB)	24.0	6	35,800

BOOM ONLY

Counterweight Extension (in)	Load Center (in)	# of Slabs	Lift Capacity (lbs)
0.0 (76" WB)	24.0	0	12,400
0.0 (76" WB)	24.0	6	18,800
36.0 (112" WB)	24.0	0	18,500
36.0 (112" WB)	24.0	6	28,000

Consult your authorized Hoist representative for a comprehensive capacity table including extended load centers and alternative slab counts and counterweight extensions.

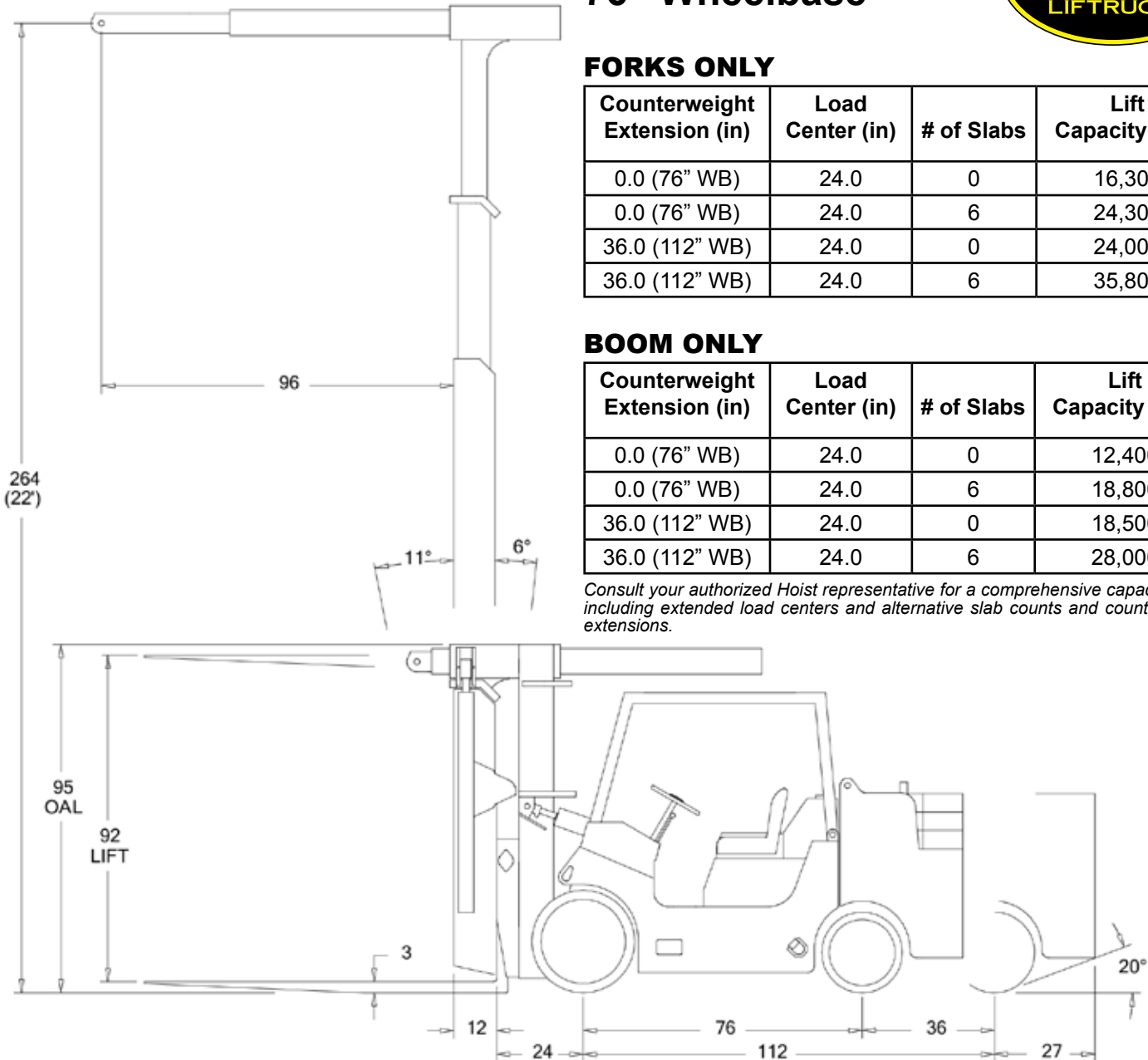

Hoist Liftruck Mfg. Inc.
6499 West 65th Street
Bedford Park, IL 60638
800-367-5600 (USA)
708-458-2200 (International)
Fax: 708-458-1176
www.hoistlift.com

The HOIST® product line is full of rugged and efficient materials-handling solutions for every aisle, dock and corner of your facility. To learn more about HOIST® products, log on to the Web at www.hoistlift.com or call us directly at 800.367.5600.

Legendary reliability: Built for robustness and designed to last, a HOIST® liftruck® will provide reliable service in the most heavy-duty applications, day after day, year after year.

Ergonomic consideration: HOIST® engineers design each operator environment for ease of use, superior visibility and comfort.

100% Replacement parts: All parts in-stock, 24 hours a day with same day shipping available.